

## Design Guidelines

For compatibility with our pick and place equipment, these are our recommendations. Although we can work with PCB's outside of these specifications, following these guidelines as closely as possible will result in a higher quality product at a lower cost per unit.

PCB's should be no larger than 18" x 14" including a 0.200" border on the long edges of the PCB. If PCBs are small or cannot provide a 0.200" border, it is recommended to place multiple PCBs on a panel. This will enable easier handling of the PCBs. The minimum size of a panel is 3.15" x 2" including border.

All panels should have at least 3 fiducials near the edges of the panel but at least 0.250" from any edge. You cannot have too many fiducials. Also there should be at least one fiducial (two recommended) within 0.250" of any fine pitch part (this fiducial can be underneath the part if space is limited.) Our recommended fiducial is a 0.040" diameter round pad surrounded by a 0.020" radius empty space. Because a fiducial is used to provide a frame of reference for the locations of the pads, a drill hole cannot be used as a fiducial as the drilling is a separate process from the etching. Remember to leave the fiducials off of the paste layer; a fiducial with paste on it is NOT usable.

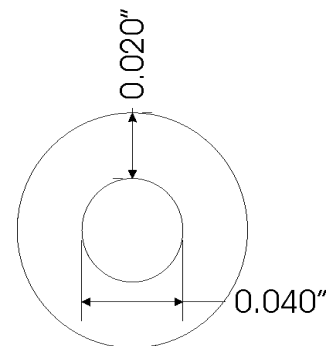
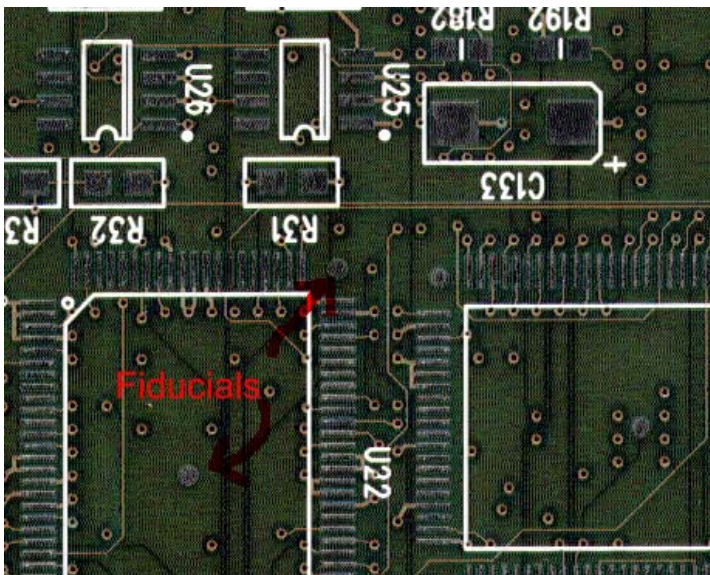

A 0.158" tooling hole should be provided 0.197" in both directions from all corners of the board.

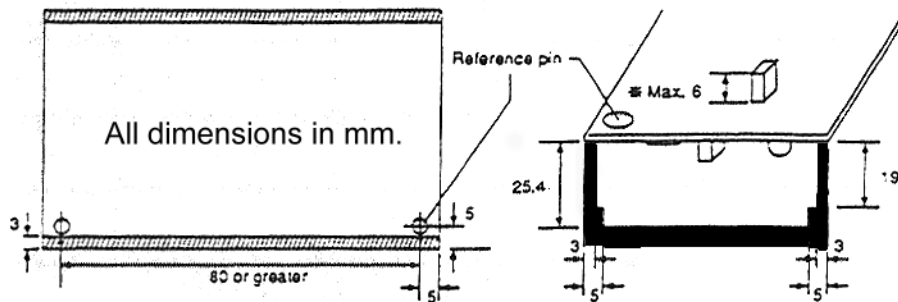

All components should be provided on tape and reel. If any part does not have a tape and reel option, waffle trays and tubes are acceptable. For programming of parts by Concisys, the parts must be supplied in tubes. We can place from 01005 parts and up, the only limit being high volume parts should be on tape and reel.

The following diagram shows the areas that parts are allowed and their height. If parts are placed in the shaded area, they must be placed by hand after both sides of the board are complete.

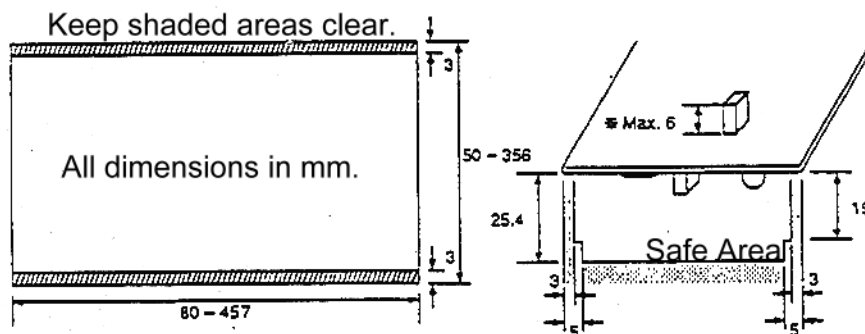

For heat sinks, TO-220 and similar parts where they must be fastened to the board, consider using eyelets (rivets) instead of screws, nuts and washers. We are fully capable of placing eyelets in your board and this will improve reliability in the long run. When deciding, ask yourself how many times you expect to remove the screw from the board. If it is only occasionally or almost never, use an eyelet, otherwise use a threaded fastener.

## Data requirements

As part of our continuing effort to improve our manufacturing efficiency, expediency, quality, and responsiveness, we have invested in Aegis Industrial Software's Computer Integrated Manufacturing software for our process. This software system converts your CAD design data and BOM data into a wide array of useful information such as robotic assembly machine programs and quality documentation more quickly and accurately than ever possible with manual methods.

In order to apply the benefits of this software to your production projects, we need your assistance in obtaining the types of data the software requires in order to function most

efficiently. This document has been prepared as a guide for your PCB design department as well as for personnel providing us with bills of material. Please provide this information as a quick reference to any and all personnel involved in providing our factory with assembly data.

Our CircuitCAM software vendor also offers their services to you in the form of consultation with your design engineers providing the CAD data, as well as the personnel providing BOM data. If for any reason this document is not adequately clear or you have any questions that are beyond its scope, please contact Aegis at 215-773-3571 and request technical support. Their service and support engineers are trained to guide you through any issues regarding your data formats.

## Section 1: BOM Import Sources and Formats

Aegis developed CheckPoint to address the challenges found in most bills of material. CheckPoint permits users to rapidly import BOMs in various source formats, to verify the BOM's integrity, and to perform both BOM-to-BOM and BOM-to-CAD comparisons. The validated CheckPoint BOM is directly transmitted to the CircuitCAM project file.

In order to successfully process your assemblies with our new CircuitCAM software, we will require a bill of material. However, more data is always beneficial in order to cope with unforeseen file difficulties, so if more information and formats are available, please provide them.

Format	Supported in...		Delimiters	Required Fields	Preferred Fields	Optional Text Fields	Optional Number Fields	Optional Boolean Fields	Custom BOM Fields	Additional Functions in CheckPoint
	CheckPoint	CircuitCAM								
Text (ASCII)	Yes	Yes	Fixed Column or Character	Part Number, Reference Designators	Description, Quantity (CheckPoint)	Part Marking, Package, Population Type, Customer P/N, Mfr, Mfr P/N, Vendor, Vendor P/N, Bin Location, Stock Code, Software Ver, Part Rev, URL	Cost, Height (mils)	Polarity, Socketed (Y/N, Yes/No, T/F, True/False)	Unlimited	Template Definition, Join Multiple Files to Form 1 BOM, Analysis Reports, Use Customer or Internal Number as Primary, AML/AVL Mgmt, Revision Control
Excel	Yes	No	N/A							
ODBC (Access)	Yes	No	N/A							

## Section 2: Board Design Data

In order to successfully process your assemblies with our new CircuitCAM software, we will require a bill of materials (refer to Section 1) and one of the following groups of board design data. However, more data is always beneficial in order to cope with unforeseen file difficulties.

### Summary Information

PCB Design Data	Format	Provides	Required?
Gerber Data	RS-274X, RS-274-D	Locations, reference designators, and board graphics	YES
Aperture List	Text File	Shape information required to render the Gerber image	RS-274-D: YES RS-274-X: NO
Centroid File	Text File	Relative locations of components (defined by reference designator) on the PCB. Allows automatic joining of references to the Gerber data.	NO: However, the use of this file expedites Gerber processing.

All CAD systems output Gerber data. Therefore, you can be assured that at least this data has been available at some time in the product's life cycle. The photo plotters used to fabricate bare boards are driven by this data exclusively, and therefore if a bare board exists, someone had access to the Gerber data at one time. Please obtain *at least one* of the sets of data listed below. (The sets are listed in order of preference, 1 being most preferred):

Set 1: Gerber RS-274X Data Files

Gerber Files to include:

§ Top Mask Layer

§ Top Silkscreen Layer

§ Bottom Mask Layer (if applicable)

§ Bottom Silkscreen Layer (if applicable)

**Optional but Highly Desirable:** ASCII text component location file (Ref, X, Y, theta)

Set 2: Gerber RS-274D Data Files

Gerber Files to include:

§ Aperture List (D-code, Shape, X-size, Y-size)

§ Top Mask Layer

§ Top Silkscreen Layer

§ Bottom Mask Layer (if applicable)

§ Bottom Silkscreen Layer (if applicable)

**Optional but Highly Desirable:** ASCII text component location file (Ref, X, Y, theta)

Set 3: ASCII Centroid File not essential but helpful if available. Most CAD systems export this file and it is sometimes identified as an "insertion", "manufacturing", or "CAM" file. It can be used as a sole CAD information source, but these files lack graphical information required for proper visual aid and documentation development.

The text (ASCII) file contains the following:

§ Reference designators

§ X coordinate

§ Y coordinate

§ Package rotation (theta)

## Section 3: CAD Data

Summary Information of Data Sources

Native CAD Data
Accel EDA , Accel Tango, & Accel PCAD
Cadence Allegro via Aegis Script
DIF (Design Interchange Format), PADS DFT Audit, and C-Link
EE Designer III ASCII File
GenCAD v. 1.4
INCASES TL CAD File
Intergraph Veribest GenCAD
IPC-D-356
Mentor Graphics Neutral File
OrCAD
PADS PowerPCB, PADS Perform, PADS 2000, PADS Work
Pantheon PDB File
P-CAD PDIF Design File
P-CAD for DOS
Protel 98/99 ASCII PCB File
SCI Cards Neutral File
Supermax CAD
Tango for DOS
Ultiboard
Valor ODB++ CAD Project
Zuken Visula and Cadstar

## Section 4: EXTRACTING NATIVE CAD DATA FROM PCB BOARD DESIGN SOFTWARE

### 1 Cadence Allegro

Extraction Procedure:

Cadence Allegro requires the use of a script available from [www.aiscorp.com](http://www.aiscorp.com)

The script produces a ccam.cad file that can then be imported into CircuitCAM.

Common File Extension: .cad

File header:

```
A!REFDES!CLASS!SUBCLASS!COMP_DEVICE_TYPE!COMP_PACKAGE!SYM_ROTATE!PIN_NUMBER!DRILL_HOLE_NAME!NET_NAME!PIN_X!PIN_Y!START_LAYER_NAME!END_LAYER_NAME!GRAPHIC_DATA_NAME!GRAPHIC_DATA_1!GRAPHIC_DATA_2!GRAPHIC_DATA_3!GRAPHIC_DATA_4!GRAPHIC_DA
```

TA\_5!GRAPHIC\_DATA\_6!GRAPHIC\_DATA\_7!GRAPHIC\_DATA\_8!GRAPHIC\_DA  
TA\_9!GRAPHIC\_DATA\_10!SYM\_NAME!SYM\_X!SYM\_Y!SYM\_MIRROR!  
J!D:\cam\102.brd!Tue Apr 25 15:21:27 2000!-100.000!-  
170.000!500.000!430.000!0.001!millimeters!B01!47.2mil!6!OUT OF DATE!  
S!!BOARD GEOMETRY!OUTLINE!!!0.000!!!!!!!ARC!-8.095!-9.949!-8.095!-9.949!-  
10.000!-  
9.949!1.905!0.000!COUNTERCLOCKWISE!NOTCONNECT!TARGET!-10.000!-  
10.000!NO!

A Cadence Allegro file can be very easily distinguished by the ! marks in the output file.  
29 data fields are required in the output file.

## 2 EE Designer III ASCII File

Common File Extension: .ala

## 3 GenCAD v 1.4 from Veribest

Extraction Procedure:

Veribest provides a stand-alone application called Report Writer. Use this application to  
export the “Mitron” export option, which causes Veribest to produce a GenCAD  
compliant output ASCII file.

Common File Extension: .cad

File Header:

\$HEADER

GENCAD 1.4

USER RSI-TRANSLATOR GENCAD OUTPUT V:10

DRAWING scm

REVISION Wed Jan 07 15:13:12 1998

UNITS USER 1000

ORIGIN 0 0

INTERTRACK 0

\$ENDHEADER

## 4 Incases TL CAD File

Common File Extension: .tl

## 5 IPC-D-356

Common File Extensions: .net or .356

File Header:

P JOB 010670x2.brd

P UNITS CUST

P DIM N

C

C Feb 11 16:26:42 2000

Company.

C IPC-D-356 Netlist From Allegro

C

327N/C - A02X-000460Y+036040X1200Y1200R000 S1

## 6 Mentor Graphics Expedition

Extraction Procedure:

Select Export under the File menu.

Select the General Interface menu item.

Select the Mitron GenCAD option.

Common File Extension: \*.cad

File Header:

See GenCAD section

## 7 Mentor Graphics Neutral File

Extraction Procedure:

Select the "Write Neutral Files" command from the Output menu of the FabLink utility.

Select to output all options.

Common File Extension: \*.neu

File Header:

```
# file : /users/ngd/pci_audio/t20318pt1/pcb/mfg/neutral_file.mech
```

```
# date : Wednesday June 10, 1998; 13:58:18
```

```
#
```

## 8 OrCAD

Extraction Procedure:

Open the OrCAD Layout Application. DO NOT OPEN the Project or the Board.

Select Export from the File menu.

Select the GenCAD option.

Browse to the location of the file and Accept.

Common File Extension: \*.cad

File Header:

See GenCAD section

## 9 PADS

- PowerPCB
- PADS Perfrom
- PADS 2000
- PADS Work

Extraction Procedure:

Through the In/Out menu, select ASCII Out (F4) command.

Select the "All" option and the PADS-2000 or PADS-3000 format.

Input the name to be used for the output file.

Common File Extension: \*.asc

File Header:

```
!PADS-POWERPCB-V4.0-BASIC! DESIGN DATABASE ASCII FILE 1.0
```

```
*PCB* GENERAL PARAMETERS OF THE PCB DESIGN
```

## 10 PANTHEON PDB File

Common File Extension: none

## 11 P-CAD

§ Accel EDA

§ Accel Tango

§ Accel PCAD

§ P-CAD for DOS

## § P-CAD PDIF Design File

Extraction Procedure:

From the File Menu select SAVE AS

Select the ASCII .PCB option

Common File Extension: \*.pcb

Extraction Procedure:

From the File Menu select Export

Select the PDIF

Common File Extension: \*.pdf

## OLD EXTRACTION

1. Select the PCAD menu from main.

2. Select PCB Tools.

3. Select the PDIF File Writer option.

4. Output a complete PDIF data file for the design. (Note that output options are not relevant to CircuitCAM

required data. The CAD user may choose any options.)

5. Select the name of the PCB file desired for export.

6. Input the name of the PDIF file to be created for input to CircuitCAM.

7. Click on Run.

Common File Extension: \*.pdf

File Header for PDF:

```
%*****
```

```
%
```

```
% Program : ACCEL P-CAD PCB Version 14.01.03
```

```
% Date : Jan 28 1999
```

```
% Time : 08:00:05 PM
```

```
% File In : c:\accel\demo\modfax0.pcb
```

```
% File Out : c:\accel\demo\modfax0.pdf
```

```
% Format : P-CAD DATABASE INTERCHANGE FORMAT
```

```
%
```

```
%*****
```

File Header for PCB:

```
ACCEL_ASCII "C:\WINDOWS\Desktop\Htrdemo.pcb"
```

```
(asciiHeader
```

```
(asciiVersion 3 0)
```

```
(timeStamp 2002 1 17 9 18 44)
```

```
(program "P-CAD 2001 PCB" "16.02.04")
```

```
(copyright "Copyright © 1991-2001 Altium Limited")
```

```
(fileAuthor "")
```

```
(headerString "")
```

```
(fileUnits Mil)
```

```
(guidString "{AA3EBDF5-111B-48FC-9292-C084E2766C15}")
```

```
)
```

## 12 PROTEL 98/99 ASCII PCB File ver 3

## Extraction Procedure:

Within Protel, select the File menu->Save As.

When in the File Format dialog, select ASCII .PCB

Common File Extension: \*.pcb

## File Header:

```
|RECORD=Board|FILENAME=D:\Shoebox\PCB_design\SwitchTest\Backup of Copy of  
SW_2.PCB|KIND=Protel_Advanced_PCB|VERSION=3.00|DATE=24-May-  
2001|TIME=11:52:14|ORIGINX=2050mil|ORIGINY=2250mil|BIGVISIBLEGRIDSIZ  
E=1000000.000|VISIBLEGRIDSIZ  
E=100000.000|ELECTRICALGRIDRANGE=0.5mil|ELECTRICALGRIDENABLED=T  
RUE|SNAPGRIDSIZESIZE=5000.000000|S  
NAPGRIDSIZESIZE=5000.000000|SNAPGRIDSIZESIZE=5000.000000|TRACKGRIDSIZESIZE=  
50000.000000|VIAGRIDSIZESIZE=200  
000.000000|COMPONENTGRIDSIZESIZE=5000.000000|COMPONENTGRIDSIZESIZE=5000  
.000000|COMPONENTGRIDSIZESIZE  
=5000.000000|CURRENTWORKINGLAYER=BOTTOM|DOTGRID=TRUE|DISPLAY  
UNIT=1|PLANE1NETNAME=(No  
Net)|PLANE2NETNAME=(No Net)|PLANE3NETNAME=(No  
Net)|PLANE4NETNAME=(No Net)|PLANE5NETNAME=(No  
Net)|PLANE6NETNAME=(No Net)|PLANE7NETNAME=(No  
Net)|PLANE8NETNAME=(No Net)|PLANE9NETNAME=(No  
Net)|PLANE10NETNAME=(No Net)|PLANE11NETNAME=(No  
Net)|PLANE12NETNAME=(No  
Net)|PLANE13NETNAME=(No Net)|PLANE14NETNAME=(No  
Net)|PLANE15NETNAME=(No  
Net)|PLANE16NETNAME=(No Net)
```

## 13 SCI Cards Neutral File

### Extraction Procedure:

From CircuitCAM you must extract a SCI-Cards Neutral file.

Common File Extension: \*.cii

## 14 Supermax CAD

Common File Extension: \*.ipl

## 15 Tango for DOS

See PCAD .pcb export.

## 16 Ultiboard

### Extraction Procedure:

Use the DDF2GenCAD convertor v1.30 supplied by Ultiboard.

Import as a Gencad File

File Header:

See GenCAD

## 17 Valor ODB++ Cad Project

### Extraction Procedure:

A .tar or a .tgz file is normally supplied containing the full directory structure of the Board.

Unzip keeping the directory structure within the .tar file.

To import browse to the MATRIX folder and select the MATRIX file.

Common File Extensions supplied by customer: \*.tar or .tgz

## 18 ZUKEN VISULA and CADSTAR

Extraction Procedure:

In the Job menu, select Interface option.

Select CADIF output from the list.

Common File Extension: \*.paf

CADstar is capable of outputting the CADIF file format.

Please use the output option for CADIF and import via the CircuitCAM Visula/CADIF interpreter.

File Header:

cadif

(format CADIF 4 0)

(design

(dataSet ARCHIVE\_XFER\_FILE\_ROUTE\_RULES\_PLACE\_RULES)

(paper (name "B"))

(box (pt -21590000 -13970000) (pt 21590000 13970000))

(DesignOrigin (pt 0 0))

**These items are mandatory for all jobs to be run on machines. If you do not have access to these files, there may be additional machine programming and setup charges.**

**We have written these guidelines to help our customers have a positive manufacturing experience. If you have any questions with any of the above items or any other manufacturing or manufacturability issues, please feel free to contact Concisys's manufacturing engineering department at (858) 205-3617**

## Frequently Asked Questions

Does this software compromise the security of our data?

No: CircuitCAM does not alter in any way your provided design data. The files are opened, scanned, and closed immediately without alteration.

**If the design is proprietary, does this software present an intellectual property risk?**

No: CircuitCAM does not extract the netlist information from any design data files.

Therefore, the information maintained within CircuitCAM's database is inadequate to reproduce the design in its entirety. Why should we bother assembling this data if it was never required before and we still receive quality product on time?

Computer Integrated Manufacturing Software like CircuitCAM enables us to improve our responsiveness to initial project setup as well as engineering changes. While Gerber files are an excellent source for fabricating stencils, it lacks the intelligence found in a CAD file. A Gerber file can be used to reach the level of intelligence found in the CAD file, but this takes significantly longer to complete and introduces the potential for human error. Furthermore, CAD file use improves the overall quality of process engineering and assembly functions. In summary, we can produce boards at our usual level of excellence without CircuitCAM—but we can be even more efficient with the software.